

Tap Boxes UK Ltd

LARGE TAP BOX DATA SHEET

Large Insulated wall mounted outside Tap Box.

Manufactured from Plastic Coated Steel.

Internal surfaces insulated. Also additional foam to be fitted over your tap.

Note: This unit is designed to help protect against fluctuations in severe weather conditions. In extreme conditions it is advisable to disconnect the tap from the water supply to avoid frost damage

SPECIFICATION

Material Plastic Coated Steel
Colour: Black

Outside measurement (overall). The box is tapered on the roof.
H 350mm. x W 270mm x D200

Insulation Insulated with 12mm Insulation.
Additional 19mm Climaflex foam insulation supplied to cover existing tap.
Thermal performance 0.033 W/mK.
Water repellent. 100%.
Complies with BS5422 insulation requirement,

2 x zip ties.
Complete with fixings

Large Tap Box - External Dimensions
For internal dimensions allow for the 12mm Insulation and 1mm steel thickness.

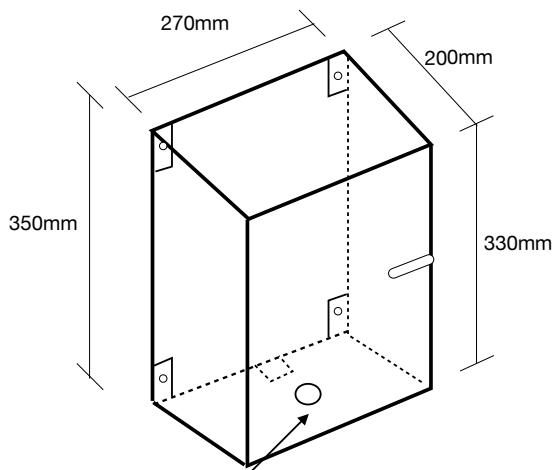

25mm Hole with rubber grommet
Set at 80mm centre from the front of the box.

